

GENERAL INFORMATION

Project Name: _____

STANDARD NSF LISTED FINISH OPTIONS

- Brushed Aluminum Chrome
- Gloss Black Wrinkle Black
- Smoked Copper Polished Brass Finish
- Other _____

GLASS THICKNESS

- 1/4" Tempered Glass (not for shelves)
Centerline Max 54"
- 3/8" Tempered Glass (for shelf or span more
than 54") Centerline Max 66"
- 1/2" Tempered Glass (for shelf or span more than
66") Centerline Max 72"

GLASS CORNERS

- 1" Radius Corner (standard)
- Square Corners

INSTALLATION OPTIONS

Above Counter: Stainless Steel Counter

Under Counter: Stainless Steel Counter

(Requires Under Counter Reinforcement & Access)

Above-Counter: Millwork Counter

Under-Counter: Millwork Counter

SS1: EZ Mount 2" x 8" Flange

SSU3-H: Heavy-Duty Flange

SSU3-N: Narrow Flange

SSU5-H: Heavy-Duty Flange

SSU5-N: Narrow Flange

MW1: Heavy-Duty Flange

MW2: Narrow Flange

MWU3: Narrow Flange

MWU4: Compression Installation
(not recommended for solid surfaces)

MWU5: Heavy-Duty Flange

ZG9560

Front Counter Installation

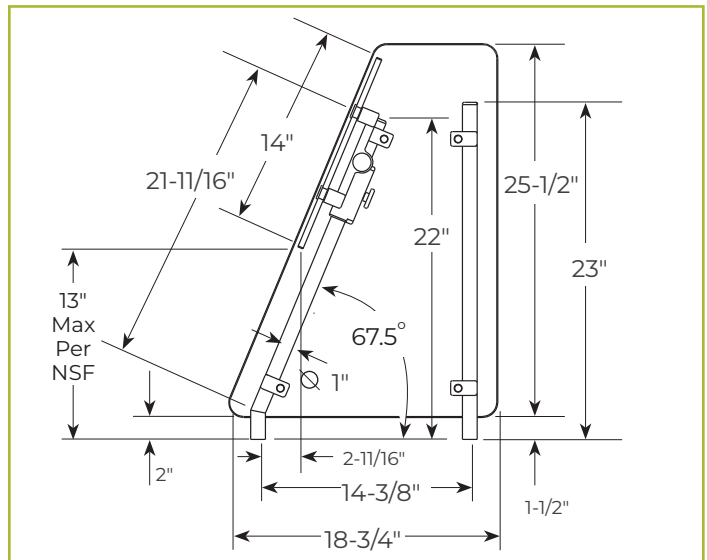
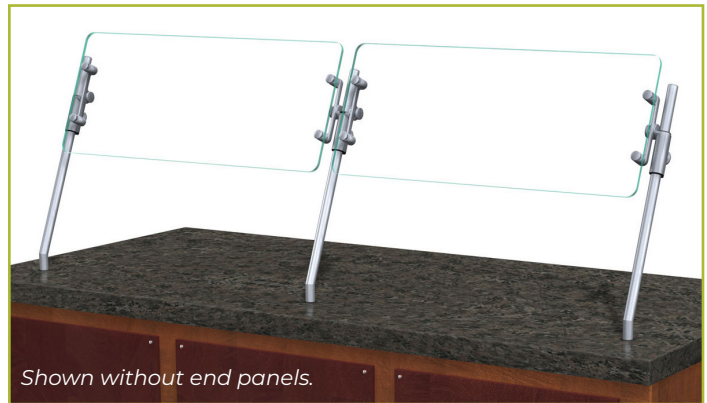

To meet NSF guidelines, end panels are included on all BSI quotations unless specifically excluded. (See End Panel Page for More Details.)